

MC8 v3.8

Table of Content

- 1 [Table of Content](#)
- 2 [Version](#)
- 3 [Overview](#)
- 4 [Introduction](#)
 - 4.1 [PDF Download](#)
 - 4.2 [Saving the manual as PDF](#)
- 5 [MIDI Message and Action Types \(Glossary\)](#)
- 6 [Concepts and Features](#)
- 7 [Important things to note](#)
 - 7.1 [Editing your presets in the editor](#)
 - 7.2 [Entering Edit Menu](#)
- 8 [Design and Architecture](#)
- 9 [Hardware Overview](#)
 - 9.1 [Powering the MC8](#)
 - 9.2 [Connections](#)
 - 9.2.1 [Rear Panel](#)
 - 9.2.2 [MIDI In](#)
 - 9.2.3 [MIDI Out](#)
 - 9.2.4 [USB port](#)
 - 9.2.5 [OMNIPOINT 1 - 4](#)
- 10 [Using External Aux Switches](#)
- 11 [Using Expression Pedals](#)
- 12 [Connecting TRS MIDI Devices](#)
 - 12.1 [Adjusting the TRS MIDI settings using Software](#)
 - 12.2 [Adjusting the TRS MIDI settings using Jumpers](#)
- 13 [Global Configuration Menu](#)
 - 13.1 [Factory Reset - Reset](#)
 - 13.2 [Align Short Name - LcdAlign](#)
 - 13.3 [Re-arrange Banks - BankArn](#)
 - 13.4 [Set MIDI Channel - MidiChnl](#)
 - 13.5 [Change OmniPort Settings - OmniPort](#)
 - 13.6 [Switch Sensitivity - SwthSens](#)
 - 13.7 [Lock dual switch presses - DualLock](#)
 - 13.8 [Bank Display Time - BankTime](#)
 - 13.9 [Bank Change Time - BnkChgDI](#)
 - 13.10 [MIDI Clock - MidiClick](#)
 - 13.11 [Save Preset Toggles - SvePstTg](#)
 - 13.12 [Long Press Time - LngPrsTm](#)
 - 13.13 [MIDI Thru - MidiThru](#)
 - 13.14 [Reset Bank Presets - RstBkPst](#)
 - 13.15 [Cross MIDI Thru - CrsMdTru](#)
 - 13.16 [Ignore MIDI Clock](#)
- 14 [General Usage](#)
 - 14.1 [Changing Banks](#)
 - 14.2 [Switch and Display Names](#)
 - 14.3 [Mapping Actions to Midi Types](#)
 - 14.4 [MIDI Thru](#)
 - 14.5 [Editing Presets](#)
 - 14.6 [Copying, Pasting and Swapping Presets](#)
 - 14.7 [Dual Switch Functions](#)
- 15 [Editing the MC8](#)
 - 15.1 [Edit Menu](#)
 - 15.1.1 [To enter the Edit Menu](#)

- 15.1.2 [Edit Menu](#)
- 15.2 [Programming Presets](#)
 - 15.2.1 [Preset Edit Menu \(Page 1\)](#)
- 15.3 [Preset Edit Menu \(Page 2\)](#)
 - 15.3.1 [Preset Edit Menu \(Page 3\)](#)
- 15.4 [Editing Preset Messages](#)
 - 15.4.1 [Selecting a Message to Edit](#)
 - 15.4.2 [Edit Action](#)
 - 15.4.3 [Edit Toggle Position](#)
 - 15.4.4 [Edit Type](#)
 - 15.4.5 [Edit Type Parameters](#)
- 15.5 [Toggle Mode](#)
 - 15.5.1 [Using the Web/Desktop Editor](#)
 - 15.5.1.1 [Toggle Name](#)
 - 15.5.1.2 [Blinking](#)
 - 15.5.2 [Using the built-in MC8 editor](#)
- 15.6 [Editing Expression Messages](#)
 - 15.6.1 [Expression Edit Menu \(Page 1\)](#)
 - 15.6.2 [Expression Edit Menu \(Page 2\)](#)
 - 15.6.3 [Edit Full Name](#)
 - 15.6.4 [Calibrating your Expression Input](#)
 - 15.6.5 [Setting your Expression sensitivity](#)
- 16 [Editing Bank Settings](#)
- 17 [Editing Names](#)
- 18 [MIDI Editor](#)
 - 18.1 [Using the Web/Desktop Editor with your MC8](#)
- 19 [Firmware Update](#)
 - 19.1 [What to download](#)
 - 19.2 [Upload instructions](#)
- 20 [Troubleshooting](#)
- 21 [MIDI Implementation](#)
 - 21.1 [PC Messages](#)
 - 21.2 [CC Messages](#)

Version

3.8.2

Overview

We take pride in making the device one of the easiest-to-use programmable MIDI controllers in the market. If there is any questions you have using the device, please do not hesitate to drop us an email at help@morningstarfx.com.

Introduction

FRONT PANEL: The MC8 has 8 switches A to H, each corresponding to the text shown closest to it on the LCD screen. By default all switches are empty and not programmed to send any MIDI messages.

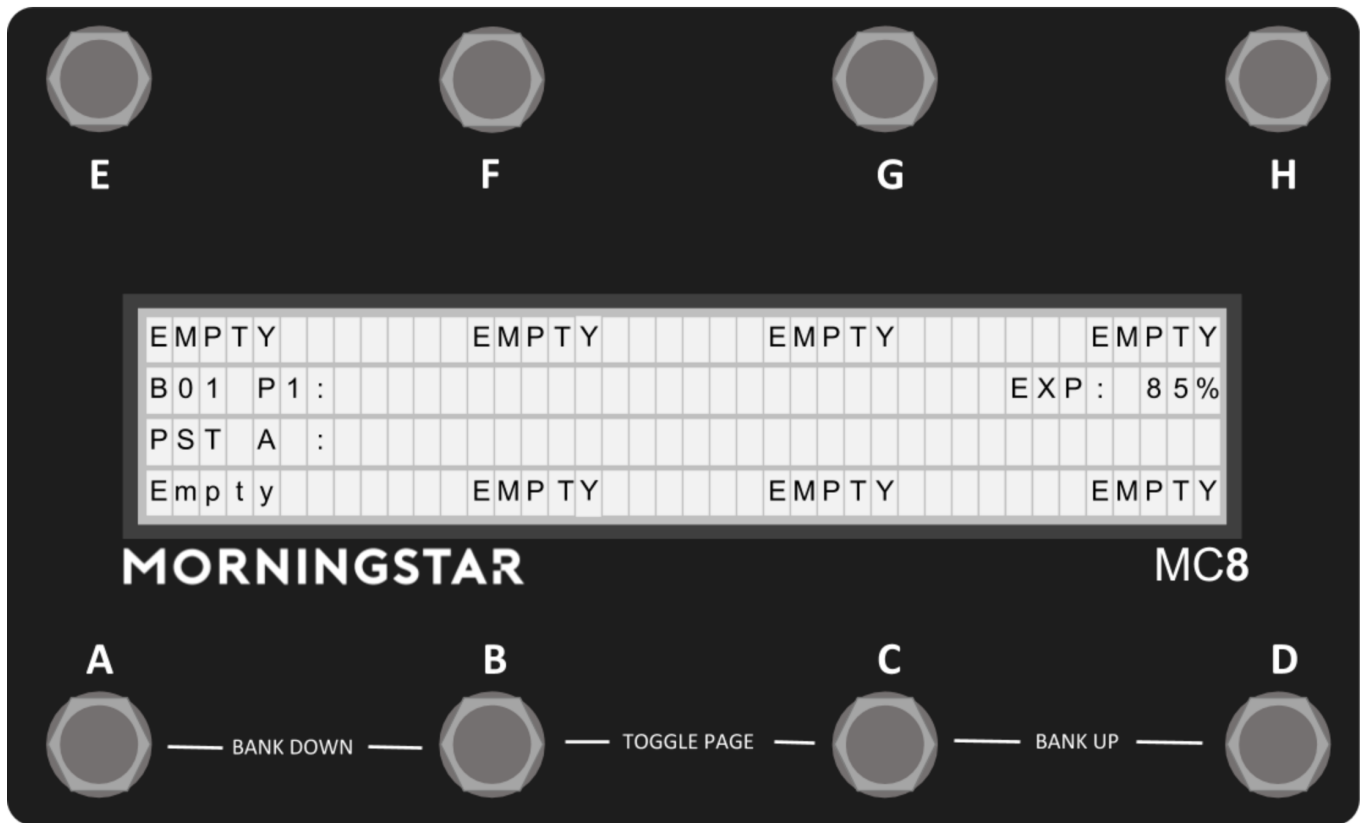

Some information is always displayed on the MC8 screen, allowing you to perform better.

They are your Bank name, Preset Name, Expression pedal position and Page.

PDF Download

PDF Manual will be published when this firmware goes live.

Saving the manual as PDF

There is an icon at the top right of this page. Clicking on it will bring out a menu with an option to export the page as a PDF document.



MC6 MKII Manual



Created by James Toh
Last updated 10 minutes ago

Table of Content

- [1 Table of Content](#)
- [2 Overview](#)
- [3 Important things to note](#)
 - [3.1 Editing your presets in the editor](#)
- [4 Design and Architecture](#)
- [5 Hardware Overview](#)



- Attachments (32)
- Page History
- Page Information
- Resolved comments
- Link to this Page...
- View in Hierarchy
- View Source
- Export to PDF
- Export to Word

MIDI Message and Action Types (Glossary)

Read about all the MIDI message types available here: [MIDI Type Glossary](#) .

Read about all the Action types available here: [Action Glossary](#) .

Concepts and Features

There are many useful functions and features on the controller to help you achieve your desired workflow. We have documented these concepts and features here: [Concepts and Features](#)

- [Adding PC Scroll Numbers to your Short Name / Toggle Name](#)
- [Using Looper Mode](#)
- [Preset Message Scroll](#)
- [Custom Bank Sequence](#)
- [CC Waveform Generators](#)
- [CC Sequencer Generators](#)
- [Using Strymon Nixie with the Morningstar Controllers](#)
- [Toggling between two or more MIDI messages](#)

Important things to note

Editing your presets in the editor

 Video tutorial available here: <https://youtu.be/NEI0EievXd0>

Make sure you are in Editor mode. Press Switch `D+E` to enter editor mode or click the 'Connect Device' button on the editor.

 When testing your device, always make sure to exit Editor Mode as some functions are disabled when your device is in Editor Mode.

Entering Edit Menu

Press Switch `E+H` in the Edit Page. The Last Used Preset, Expression Pedal Input and Bank will be displayed in the menu.

 Make sure to exit Editor mode to have the full functionality available before you use it with your devices.

Design and Architecture

The MC8 is a fully programmable MIDI controller, capable of controlling up to 16 MIDI devices per switch.

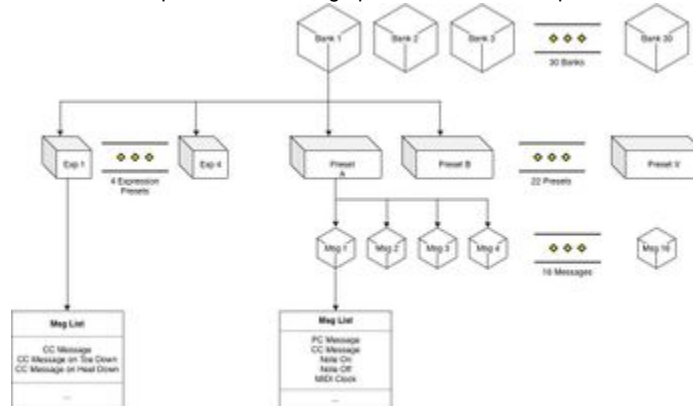

There are 30 banks. Each bank has 22 presets and 4 expression presets. Each preset can be programmed to send out 16 different messages.

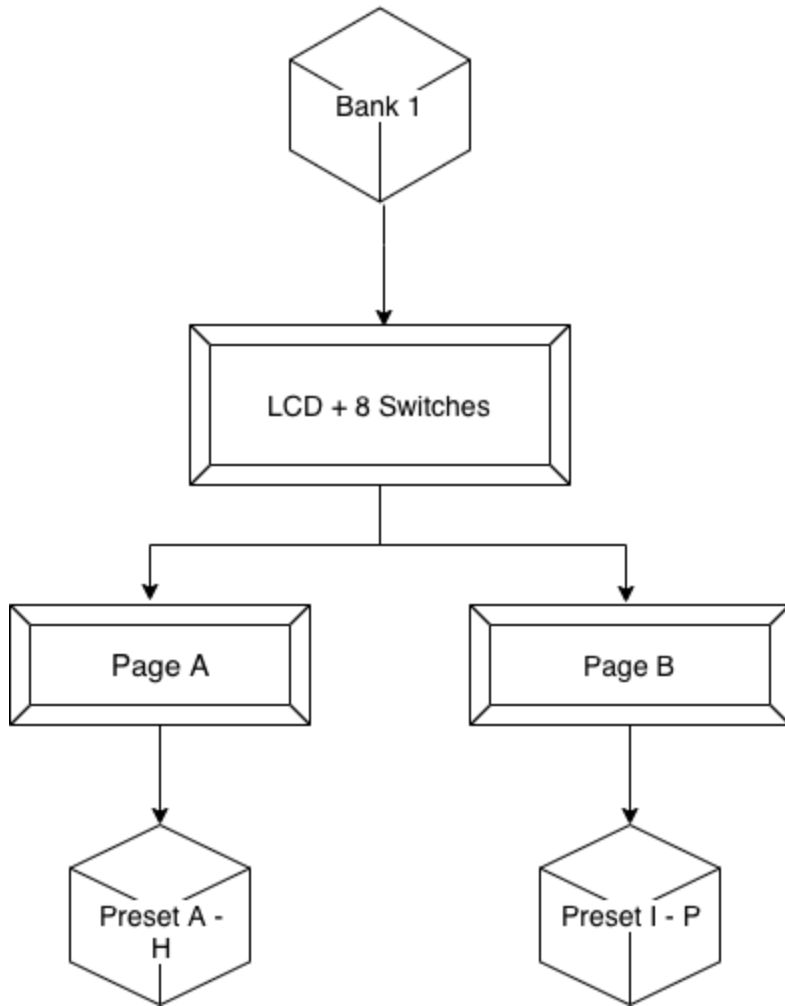

Each bank can display up to 8 presets, of which all are accessible from the 8 switches. The other 8 presets can be engaged via dual switch presses or external aux controllers. A Page Toggle function is also available via *Switch B+C* to switch between the first 8 presets and the last 8 presets.

Besides these 16 presets, the *OmniPort 1* and *OmniPort 2* can control *Presets Q-S* and *Presets T-V* respectively with an external 3 switch aux controller attached.

Hardware Overview

Powering the MC8

i Your MC8 device can be powered via the multiple methods.

w Please ensure that your power supply can supply at least 250mA at 9VDC.

9VDC Centre Negative power supply

Connect a 9VDC centre negative power supply to the power input of the MC8.

i The MC8 requires at least 250mA of power at 9VDC.

Phantom Power (9-12v AC or DC)

Connect a 7-pin Midi cable to the MIDI OUT port of the MC8. Phantom power is supplied through pins 6 and 7. Phantom power is chained to pins 6 & 7 on the MIDI IN port as well, allowing you to power other devices.

If sending DC power via the pins, the polarity does not matter.

USB power

Connect a USB cable to the MC8. The MC8 is capable of being fully powered by USB.

Connections

Information on all the inputs and outputs on the MC8.

Rear Panel

On the rear panel, you will find 4 Omni Ports (1/4 inch TRS) that can be independently configured to be Expression Pedal inputs, Aux Switch inputs or MIDI outputs.

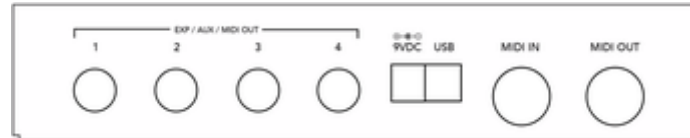

MIDI In

This is where the MC8 receives MIDI messages from other MIDI devices.

The MC8 passes incoming MIDI messages via the MIDI In/Receive port out to the USB port, and vice versa.

MIDI Out

This is where MIDI data is sent from the MC8 to other devices. You can use a standard 5-pin MIDI cable, or a 7-pin one if you have a device that provides phantom power via pins 6 & 7.

The MC8 implements a soft MIDI Thru, where incoming MIDI messages are processed and can be sent out again via the MIDI Out port.

USB port

The MC8 can also send and receive MIDI data via USB, allowing you to have control over your DAWs and music software. It is class compliant and compatible with Windows, macOS, Android and iOS.

The MC8 can pass certain incoming MIDI messages (PC, CC and Note messages) via the MIDI In port out to the USB port, and vice versa.

OMNIPORT 1 - 4

The `OmniPorts` has the ability to

- Send MIDI messages via TRS,
- Be used with an Expression Pedal
- Be used with an Aux Switch (up to 3 switches)

You can connect your expression pedals to these ports to control the expression presets, or connect aux switches to add more programmable switches to the MC8.

Please note that these ports are `INPUT` only, and cannot be using to control functions like amp switching or sending Control Voltage messages. You should only be connecting an expression pedal or TRS passive Aux Switches to these ports.

You should only use **STEREO CABLES**. Using Mono cables will cause the device not to work as intended.

 Applying power to the OMNIPORT inputs might damage your device.

Using External Aux Switches

You can connect an external Aux switch to your MC8 to control extra presets:

- OMNIPOINT 1: Preset Q R S
- OMNIPOINT 2: Preset T U V
- OMNIPOINT 3: Preset I J K
- OMNIPOINT 4: Preset L M N

The MC8 requires an aux switch that is wired like the schematic below. It has to be connected to the device with a stereo cable, where the Tip is connected to the ground via a SPST Footswitch, and similar to the Ring as well. Another switch can be added to connect both Tip and Ring to ground to engage an additional preset/setting. Please refer to the schematic below.

There are a few pedal builders that sell such devices:

[Analog Endeavors](#)

[American Loopers](#)

Please note that we are in no way affiliated with these companies.

If you would like to build one yourself, you can refer to the following schematic:

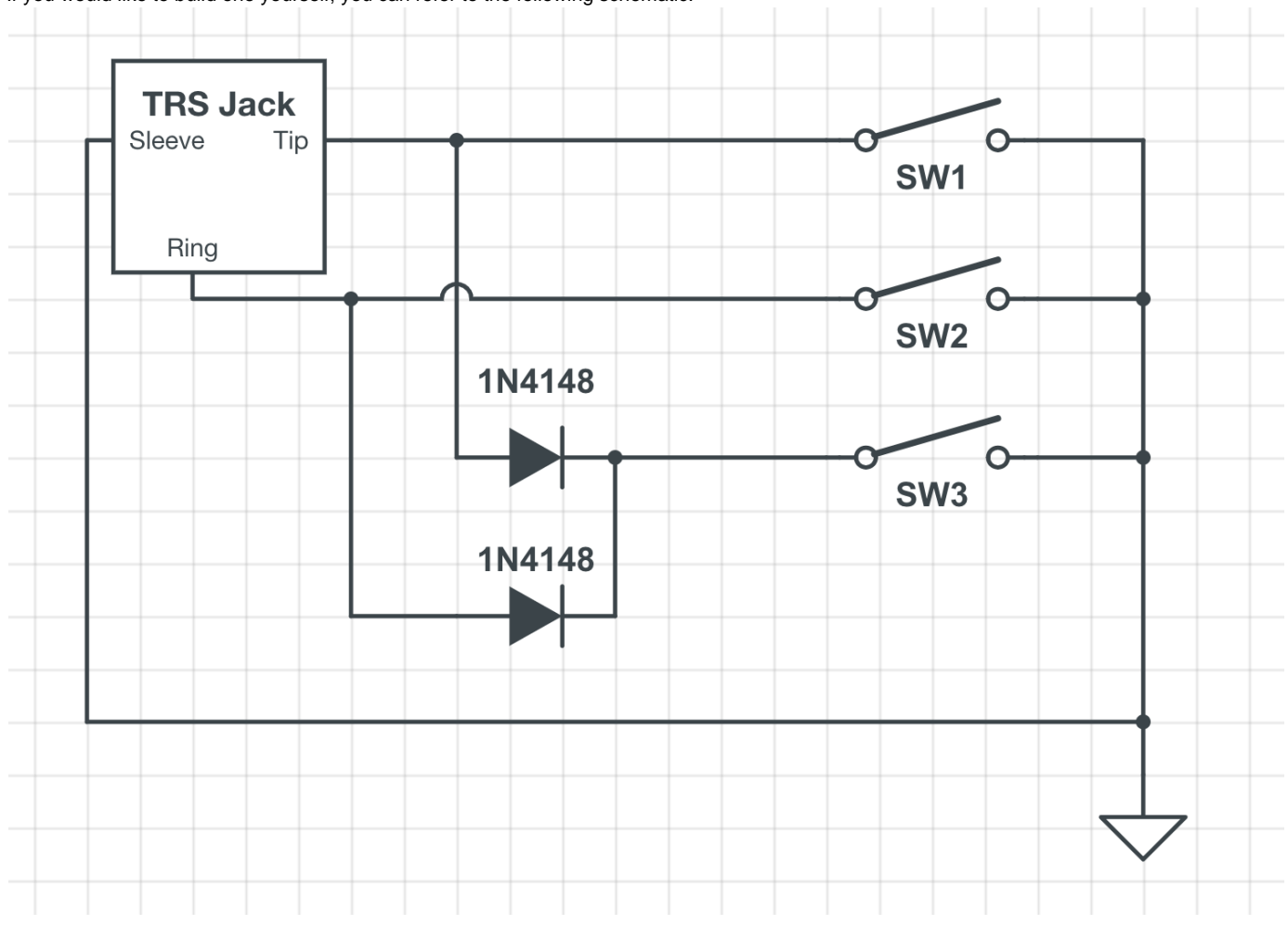

Using Expression Pedals

Video tutorial available - <https://youtu.be/-TNTkqh-gEE>

Before using the expression pedal, check to make sure that your Omniport input settings are set to `ExprnPedal`. You can access this menu by going to the `Global Configuration Menu >> OmniPort`.

The MC8 work with TRS expression pedals. It works best with expression pedals fitted with 10k - 25k Linear potentiometers. The potentiometer wiper should be connected to the Tip of the stereo cable, while the Ring and Sleeve should be connected to the outer lugs on the potentiometer.

When connecting a new Expression pedal, be sure to **calibrate** it first by going into the Edit menu (Switch E+H), selecting Exp1 | Exp2 | Exp3 | Exp4 and then Calibrate.

Connecting TRS MIDI Devices

Adjusting the TRS MIDI settings using Software

In Firmware v3.8 onwards, the Omniport TRS MIDI settings no longer requires the backplate to be removed and jumpers adjusted. The TRS settings can be adjusted via software in the device itself or using the Editor.

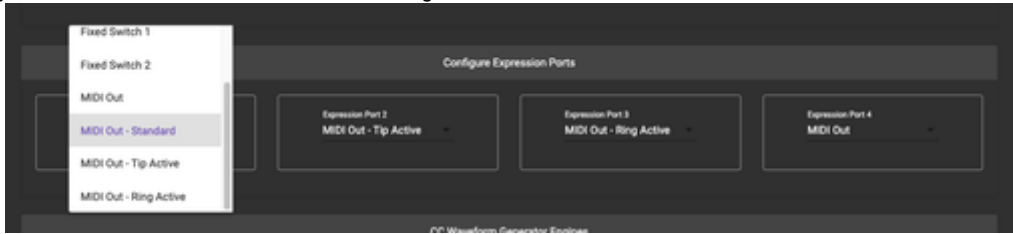

In the editor, there are 3 new options are listed related to using the Omniports as MIDI Out.

- **MIDI Out** : Default setting which uses the jumper arrangement (See below)
- **MIDI Out - Standard** : Sends MIDI on the Tip and Power on the Ring
- **MIDI Out - Tip Active** : Sends MIDI on the Tip and Ring is left floating
- **MIDI Out - Ring Active** : Sends MIDI on the Ring and Tip is left floating

Adjusting the TRS MIDI settings using Jumpers

You can also use the Omniports to send TRS MIDI. To do so, you simply need to go into the Global Config Menu >> Omniport and then change the desired Omniport to **MIDI OUT**. Upon the device restarting, the Omniport will be configured to send MIDI out.

By default, the MIDI out is configured to send MIDI via TRS, where the MIDI signal is sent on the Tip and 3.3v power is sent on the Ring.

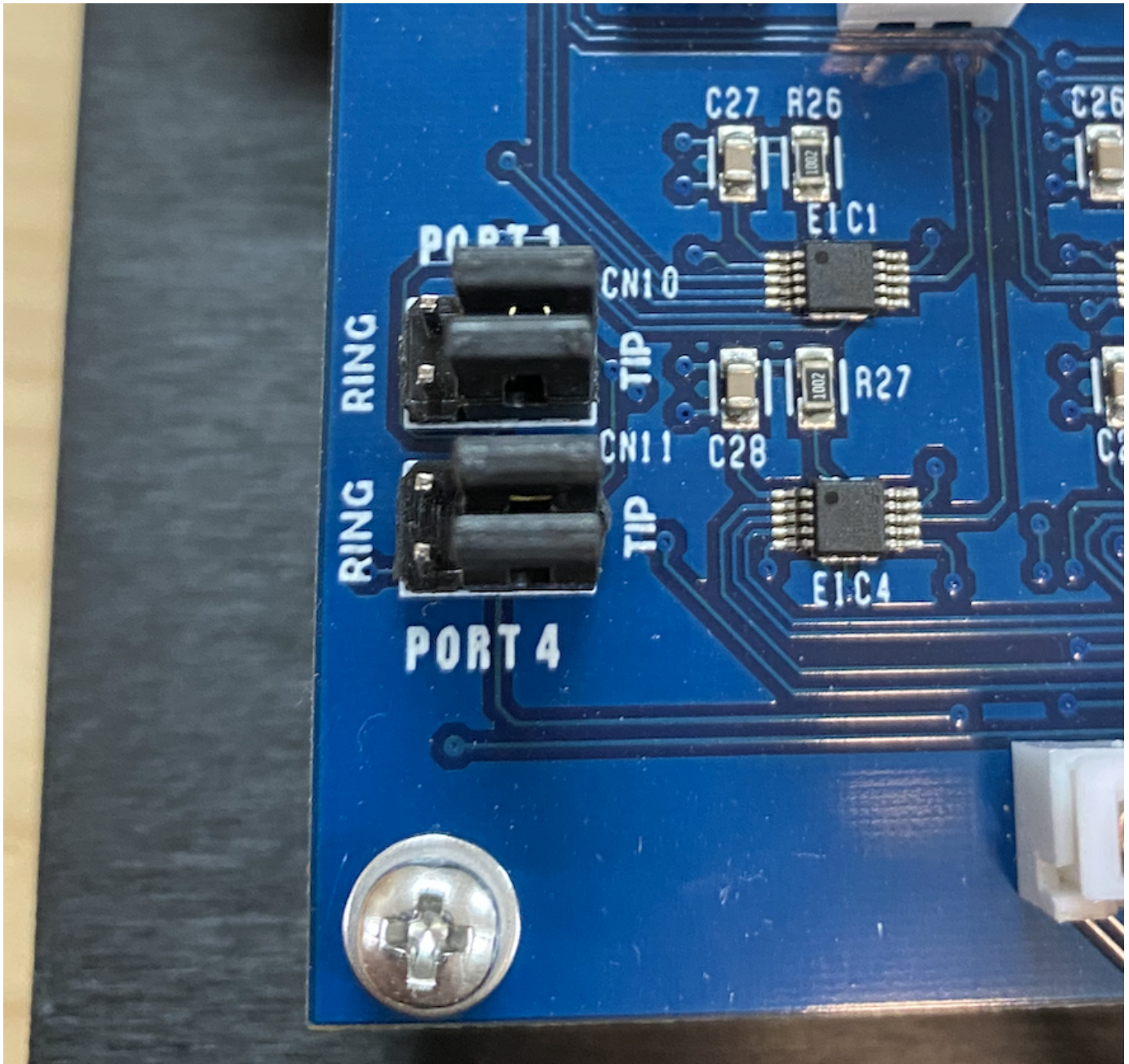

However, devices such as Chase Bliss uses a different configuration, where the MIDI signal is received at the Ring and the Tip is left floating. The MC8 can accommodate this, but this requires removing the back plate of the MC8 and

1. Removing the bottom jumper
2. Shifting the top jumper to the left

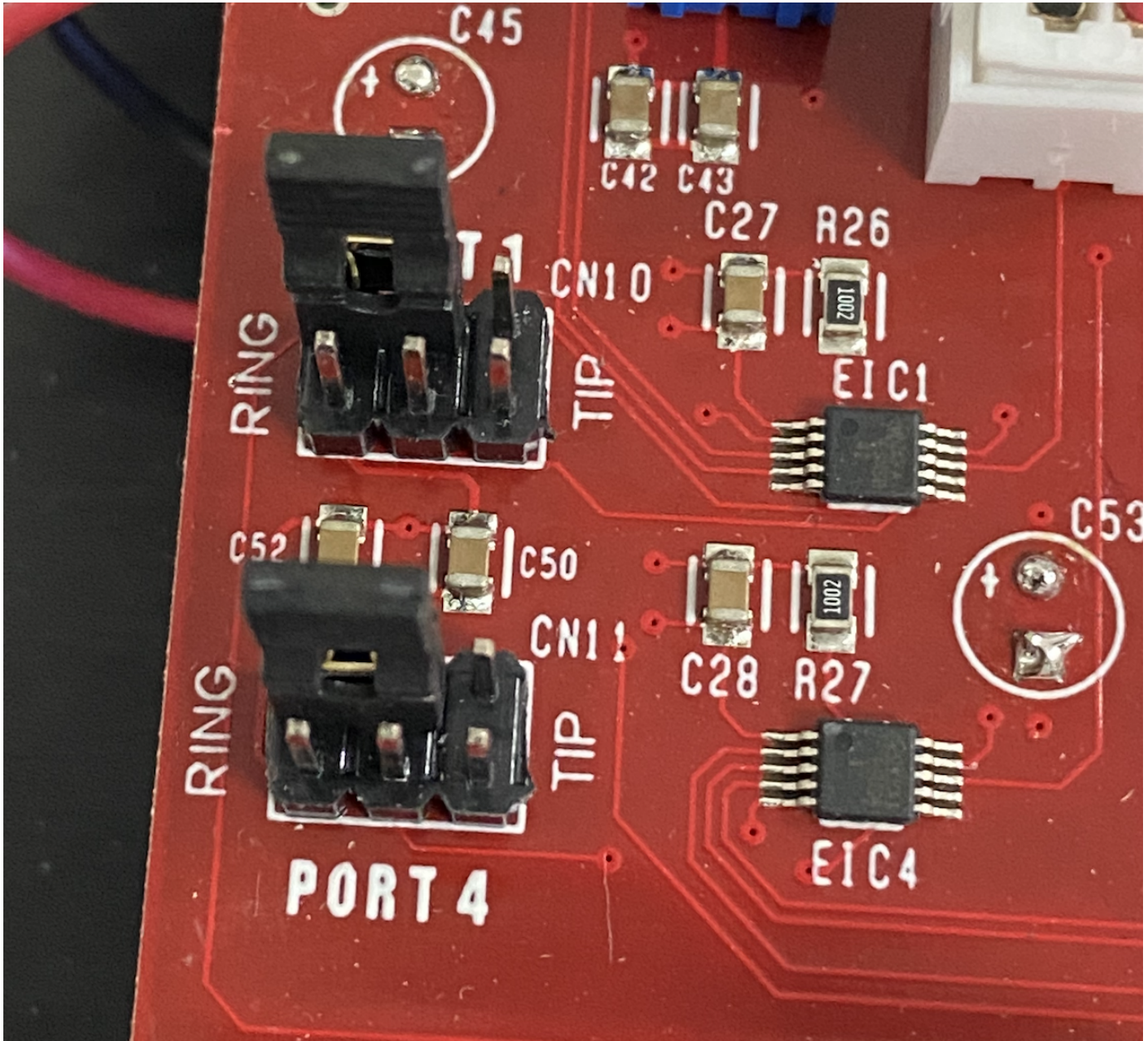

In the image above, Port 1 and Port 4 are configured to send MIDI to Chase Bliss devices.

For Meris pedals, only the Tip should be connected to Data while the Ring is left floating. The image below shows Port 4 configured to send Data to the Tip only.

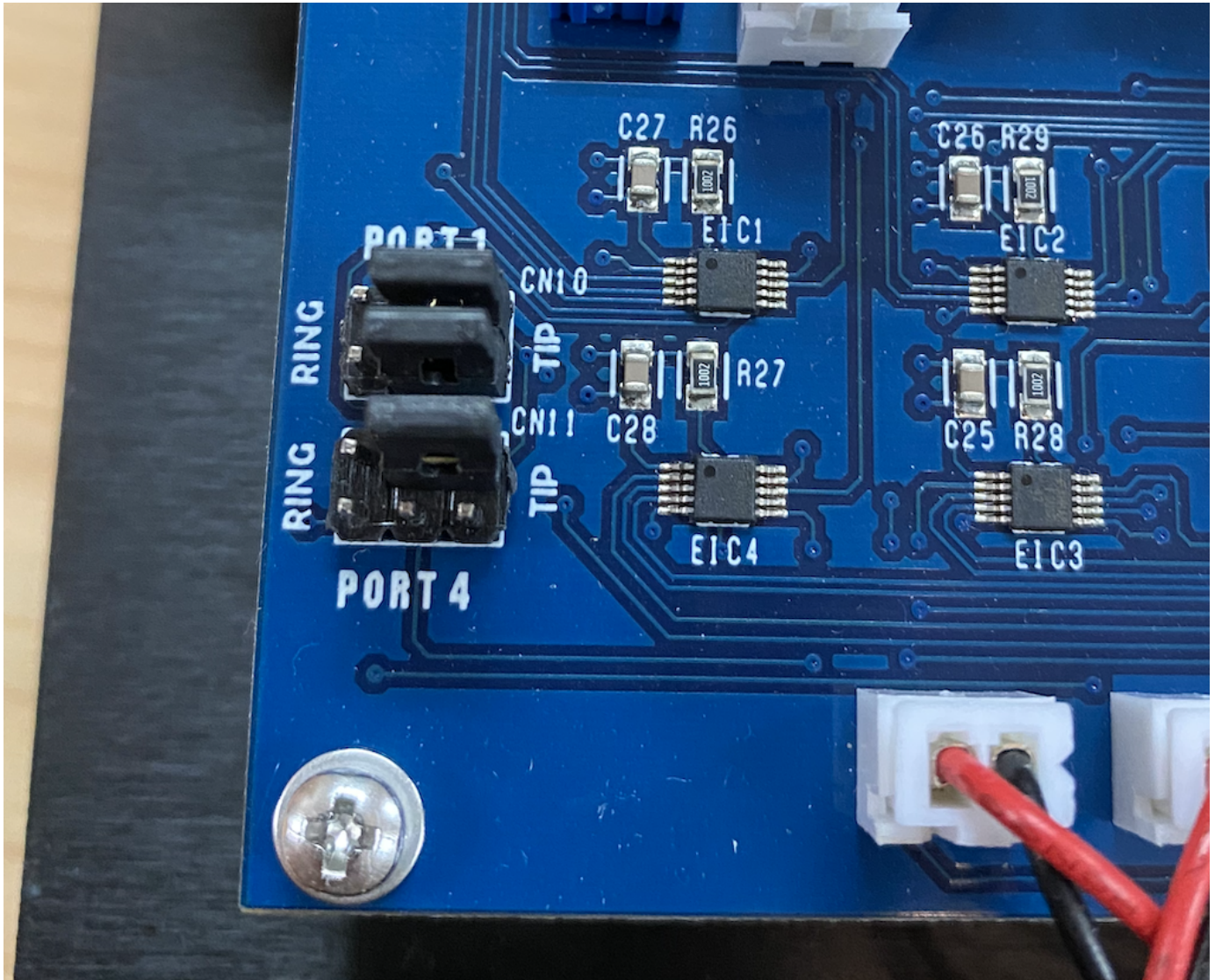

⚠ Remove the backplate screws carefully to avoid damage. If you find that the screws are too tight, you should try to loosen the 4 Omniport nuts first before removing the screws.

Global Configuration Menu

To access the Controller Settings Menu, hold down Switch **E** before powering up the MC8. This menu allows you to edit the global settings for the device.

The Main Configuration Menu can also be accessed by going into the Edit Settings page (Switch **E+H**) and selecting **ConfigPg**.

⚠ Please note that the controller will restart after exiting the Global Configuration Menu.

The display will indicate that it is booting into the configuration page, and the menu below will be displayed:

```
(MidiClck)( Reset )(DualLock)(NextPage)
[Global Configuration Menu]

(OmniPort)(SwthSens)(MidiChnl)( Exit )
```

You can select **NextPage** to view more options in the menu.

```
(BankArng) (NextPage)
[Global Configuration Menu]

(BankTime)(BnkCh9D1)(LcdAlign)( Exit )
```

Factory Reset - Reset

To do a factory reset, hold down for 2 seconds. The display will show that it is performing a factory reset. All user presets and settings will be reset to factory default when a reset is done.

Align Short Name - LcdAlign

When LcdAlign is turned on, your Preset Short Names will be aligned, depending on its position on the LCD. For example, Preset A name will be aligned to the left, while Preset D name will be aligned to the right.

Re-arrange Banks - BankArn

Your banks can be re-arranged in this menu. More info [here](#).

Set MIDI Channel - MidiChnl

Set the MIDI receive channel for the MC8. The MC8 can receive and respond to messages from external midi controllers. Press Switch H or Switch D to increase or decrease the MIDI channel respectively.

Press **Save** to save your settings and **Exit** to exit.

Change OmniPort Settings - OmniPort

Change the device Expression Input Type and select between **Aux Switch**, **Expression**, **MIDI Out**, **Fixed Sw 1** or **Fixed Sw 2** Setting.

- **Aux Switch**
 - Use a stereo cable to connect to an external aux switch to control more presets.
- **Expression**
 - Connect an expression pedal via a stereo cable (Tip connected to wiper) to engage the expression preset.
- **MIDI Out**
 - Sends MIDI out via TRS. The MIDI signal is sent via the **TIP** by default. There are jumpers in the circuit board which allows you to change to **RING** to control devices from Chase Bliss Audio.
- **Fixed Sw 1**
 - Similar to the aux switch, but the functions are hard-coded to control the Bank Up, Bank Down and Toggle Page functions without sacrificing any presets.
 - **Tip** = Bank Up
 - **Ring** = Bank Down
 - **Tip + Ring** = Toggle Page
- **Fixed Sw 2**

- Similar to `Fixed Sw 1` but the Bank Up and Bank Down are reversed.

Switch Sensitivity - `SwthSens`

Set switch sensitivity. Choose from 1 (least sensitive) to 5 (most sensitive). Pressing `Switch B+C` will select 3.

i By default, this is set to 3 and should be comfortable for most users. Depending on personal taste, you may adjust sensitivity to help you bank up/down (by stepping on 2 switches at once) more accurately.

More sensitive means that the lag between the time when a message is sent out and when the switch is pressed it at its minimum.

Lock dual switch presses - `DualLock`

When the dual lock setting is turned on, dual switch press functions like Bank Down, Bank Up and Toggle Page will be disabled.

Bank Display Time - `BankTime`

This setting adjusts the amount of time the bank details will show when the bank is changed.

The value displayed is in milliseconds.

Bank Change Time - `BnkChgDl`

This setting adjusts the time it takes to load the next bank when the bank is changed.

The value displayed is in milliseconds.

MIDI Clock - `MidiClck`

The MIDI clock setting toggles the persistent MIDI clock function ON and OFF. This setting is related to the MIDI Clock message under MIDI Types. If persistent MIDI is ON, the MIDI Clock message will continue sending a MIDI clock signal when engaged, even when engaging other presets or scrolling through banks. However, if persistent MIDI is OFF, the MIDI clock signals will shut off when an event (like a switch press or expression pedal move) is triggered.

⚠ When MIDI Clock Persistence is on, you might encounter some timing changes for a short period when engaging functions on the MC8, like changing banks and invoking presets. If you do not need the MIDI Clock after your devices have synced to the tempo, we would recommend that you turn off MIDI Clock Persistence.

Save Preset Toggles - `SvePstTg`

Determine whether preset toggle states are remembered when you change banks. If set to `ON`, your preset toggle states will be preserved when you change banks. When set to `OFF`, your preset toggle states will be reset when you change banks.

Long Press Time - `LngPrsTm`

Sets the amount of time (in milliseconds) you need to hold down the switch in order to trigger a Long Press action.

MIDI Thru - `MidiThru`

Enables the passing thru of all MIDI messages from the MIDI IN port to the MIDI OUT port.

Reset Bank Presets - `RstBkPst`

This resets all the Bank Presets to empty.

Cross MIDI Thru - `CrsMdTru`

Enables the passing thru of certain MIDI messages from DIN5 MIDI Input to USB MIDI Output, and USB MIDI Input to DIN5 and TRS MIDI Outputs.

Not every MIDI message is supported. The supported MIDI messages are PC, CC, Note On, Note Off, Pitch Change and After Touch messages.

Ignore MIDI Clock

If Ignore MIDI Clock is enabled, the controller will ignore any incoming MIDI clock messages from the USB port. If disabled, any incoming MIDI clock messages from the USB port or MIDI IN port will set the controller's MIDI Clock BPM, and the controller will then generate MIDI Clock messages to be sent out.

General Usage

Changing Banks

Step on Switches A+B together to bank down and Switches C+D to bank up. There are a total of 30 banks on the MC8.

Bank Changes can also be executed by programming a Bank Change function to a preset, or by using an External Aux Switch.

Switch and Display Names

Each switch corresponds to the display name closest to it.

Pressing Switch A activates Preset A, Switch B activates Preset B and so forth.

Mapping Actions to Midi Types

The MC8 allows you to map actions taken on the switches to MIDI Types and functions. For example, you can map a CC#1 message to a Press action, and a CC#2 message to a Release action. When the switch is pressed, a CC#1 message will be sent, and when the switch is released, a CC#2 message will be sent. There is a list of actions available to you.

1. Press
2. Release
3. Long Press
4. Long Press Release
5. Double Tap
6. Double Tap Release
7. Long Double Tap
8. Long Double Tap Release
9. Release All
10. Long Press Scroll

More information can be found in the <https://morningstarengineering.atlassian.net/wiki/pages/createpage.action?spaceKey=MC6MKII&title=Action%20Glossary> .

MIDI Thru

The MC8 can be programmed to pass incoming MIDI signals from the MIDI IN port to the MIDI OUT port. It can also pass CC, PC and Note messages thru to the USB port. The MC8 will also pass incoming CC, PC and Note MIDI signals from the USB MIDI port to the MIDI OUT port.

You can toggle this setting on and off by pressing Switches A+H together.

Editing Presets

Both the Switch Presets and Expression Presets on the device can be edited via the **on-board editing functions** or the **Web/Desktop Editor**.

Copying, Pasting and Swapping Presets

The device allows copying and pasting of presets into different presets. These options are available in the device itself (E+F >> Preset >> Copy, Paste, Swap).

The Paste and Swap functions will work with the previously copied Preset.

Dual Switch Functions

The MC8 makes use of dual switch combination to carry out certain functions.

Function	Switch
Bank Down	A+B
Bank Up	C+D
Toggle Page	B+C
Edit Menu	E+H
Toggle Editor Mode	D+E
Toggle MIDI Thru	A+H

Besides this, you can also use dual switch presses to call the extra presets.

In Page-1:

Preset	Switch
Q	E+F
R	F+G
S	G+H

In Page-2:

Preset	Switch
T	E+F
U	F+G
V	G+H

Editing the MC8

The MC8 can be programmed on the device itself, or by using the Web/Desktop Editor. In this section, we will go through the steps of editing a preset on the device itself.

Edit Menu

On a new controller, all switches are initially labelled as `EMPTY`. It is up to you to decide exactly what each one will do.

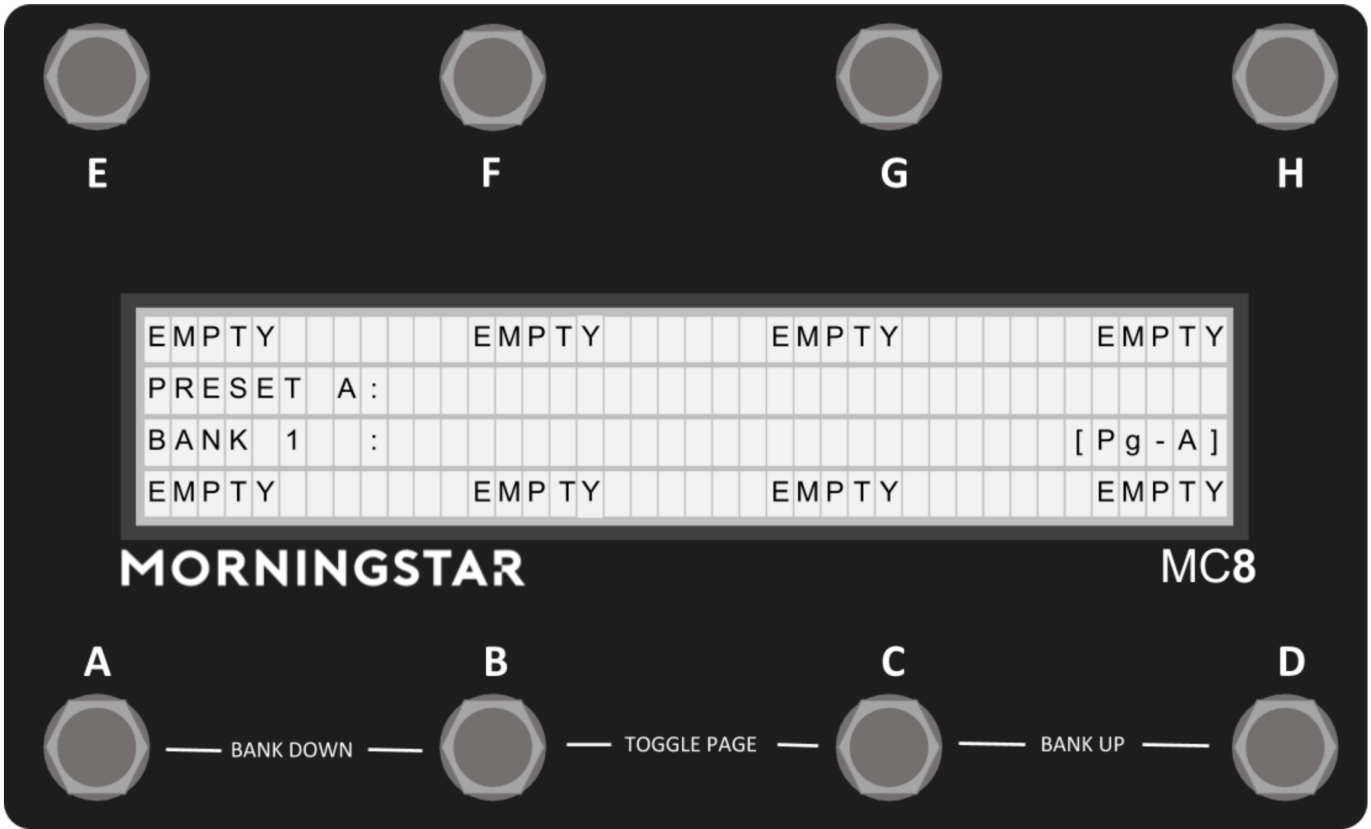

To enter the Edit Menu

1. Press the switch you wish to program
2. Press Switch E+H together. This will take you to the Edit Menu shown below.

Edit Menu

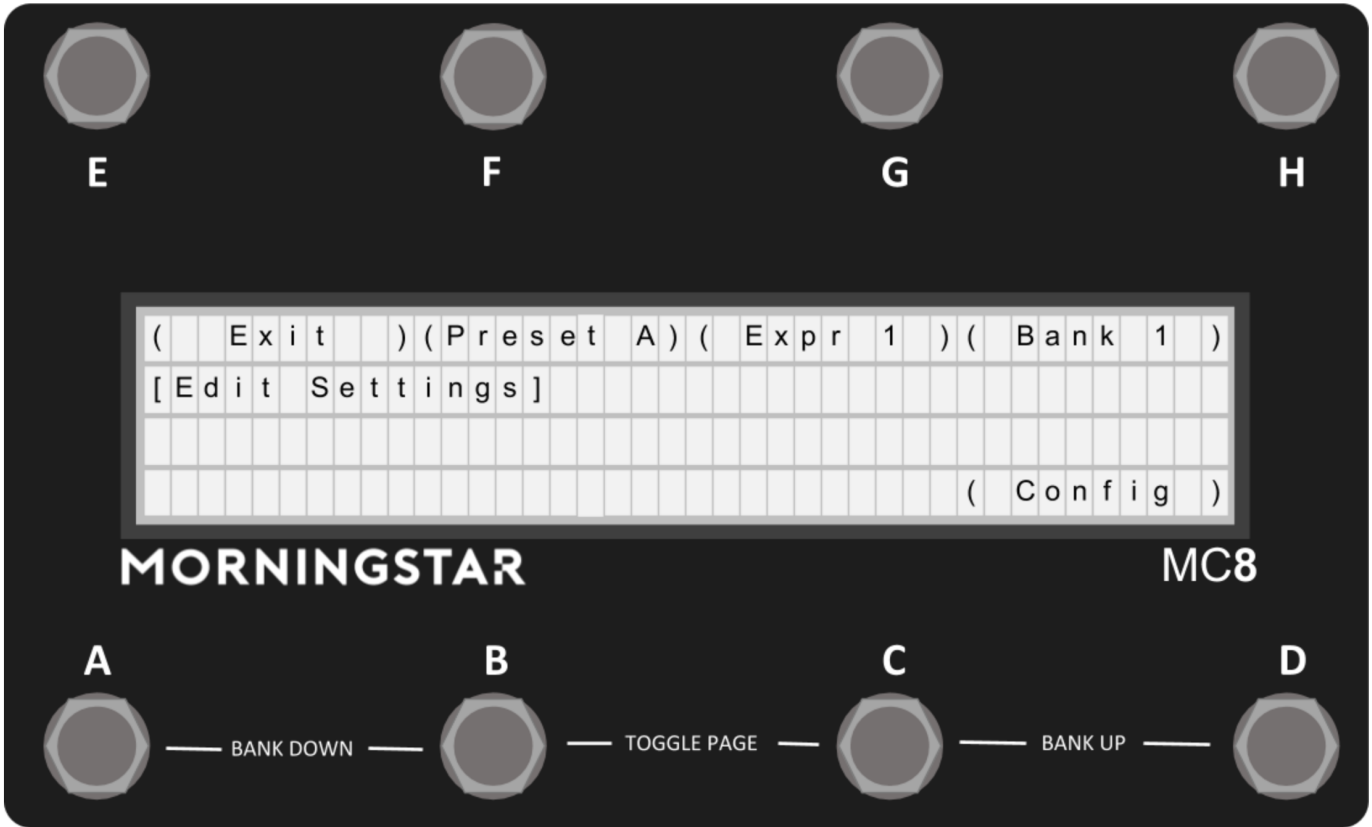

After pressing Switches E+H, the Edit menu will be displayed. The preset and expression you last used will be displayed, as well as the bank you are currently on.

Press Switch F to edit the preset, Switch G to edit the expression preset, or Switch H to edit the bank.

Programming Presets

i Upon pressing Preset in the Edit Menu, you will be directed to the Preset Edit page.

Preset Edit Menu (Page 1)

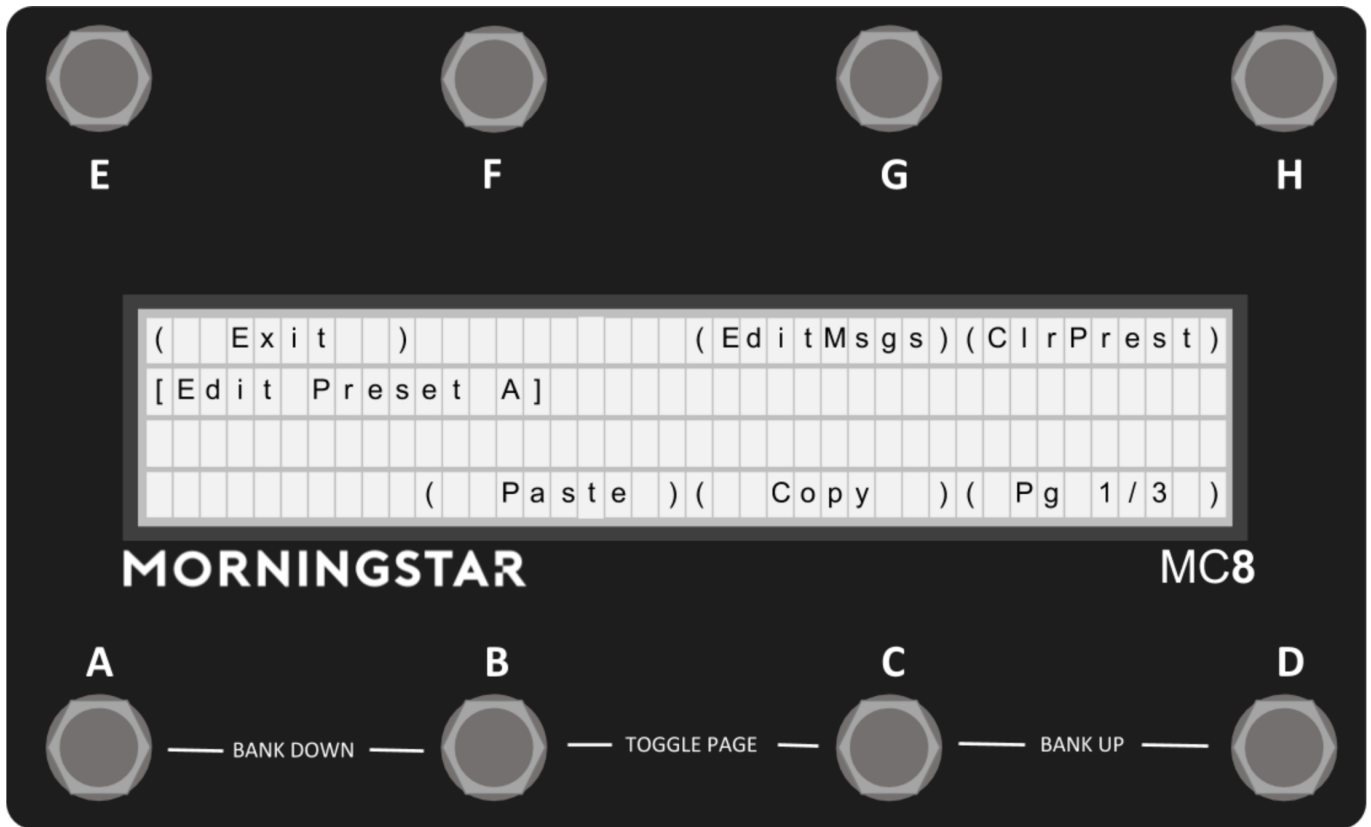

(EditMsgs) - Edits the 16 Midi Messages available in the preset.

(ClrPrest) - Clear the preset settings.

(Copy) - Copy the preset settings

(Paste) - Paste the copied preset settings to the currently selected switch. **!** Holding down 'Paste' will paste the copied preset settings to all banks.

(Swap) - Swap the copied preset settings to the currently selected switch.

(Pg 1/3) - Shows the current page in the menu. Press to go the next page.

(Exit) - Exits the menu.

Preset Edit Menu (Page 2)

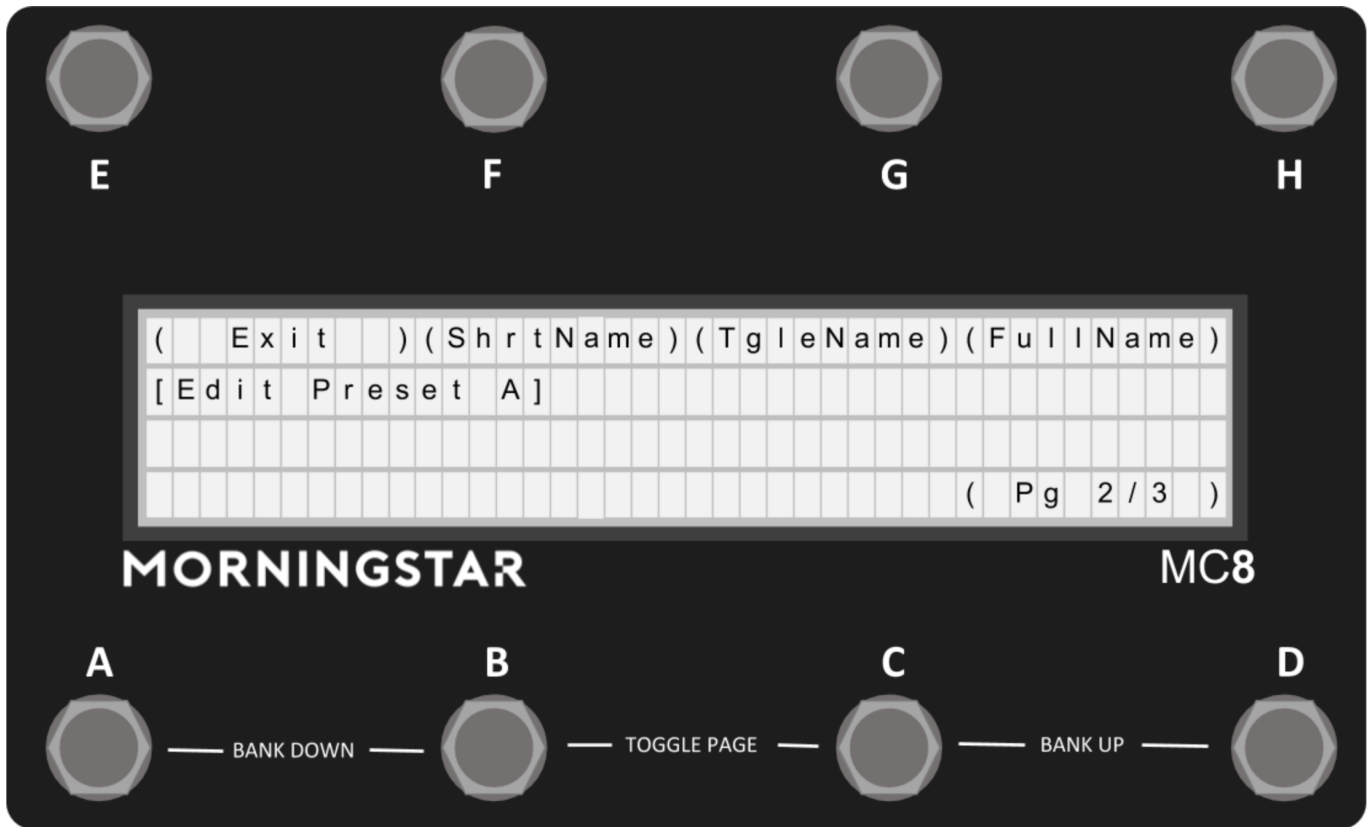

(ShrtName) - Edits the preset short name. Look at Editing Names for more information on how to edit any names in the MC8.

(Tg leName) - Edits the preset toggle name. Look at Editing Names for more information on how to edit any names in the MC8.

(FullName) - Edits the preset full name. Look at Editing Names for more information on how to edit any names in the MC8.

(Pg 2 / 3) - Shows the current page in the menu. Press to go to the next page.

(Exit) - Exits the menu.

Preset Edit Menu (Page 3)

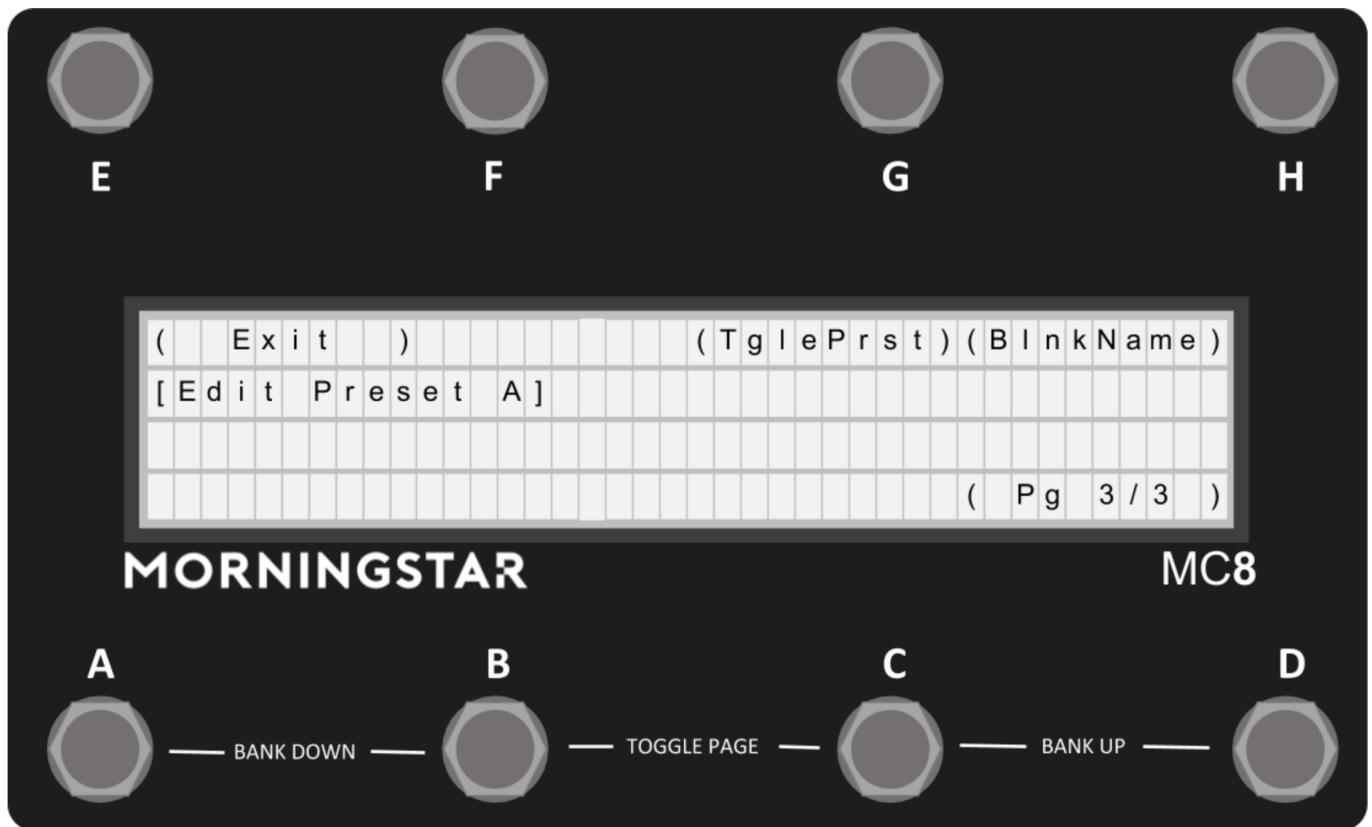

(TglePrst) - Toggles between On and Off for the preset toggle setting. If On, each time the preset is engaged, the toggle position of the preset will change. The Midi Messages in the preset will rely on the toggle position of the preset to determine if it should be invoked.

(BlnkName) - Toggles between On and Off for the preset blink setting. If On, the preset short name will blink when the preset toggle is in the engaged position. This is useful to visually determine the toggle state of your preset.

(MsgScrl1) - Toggles between On and Off for the Message Scroll mode. If Message Scroll is On, the Preset will scroll through each of the 16 Messages in the Preset that is programmed with a RELEASE action.

(Pg 3 / 3) - Shows the current page in the menu. Press to go to the next page.

(Exit) - Exits the menu.

Editing Preset Messages

i The MC8 has 16 Messages in each Preset.

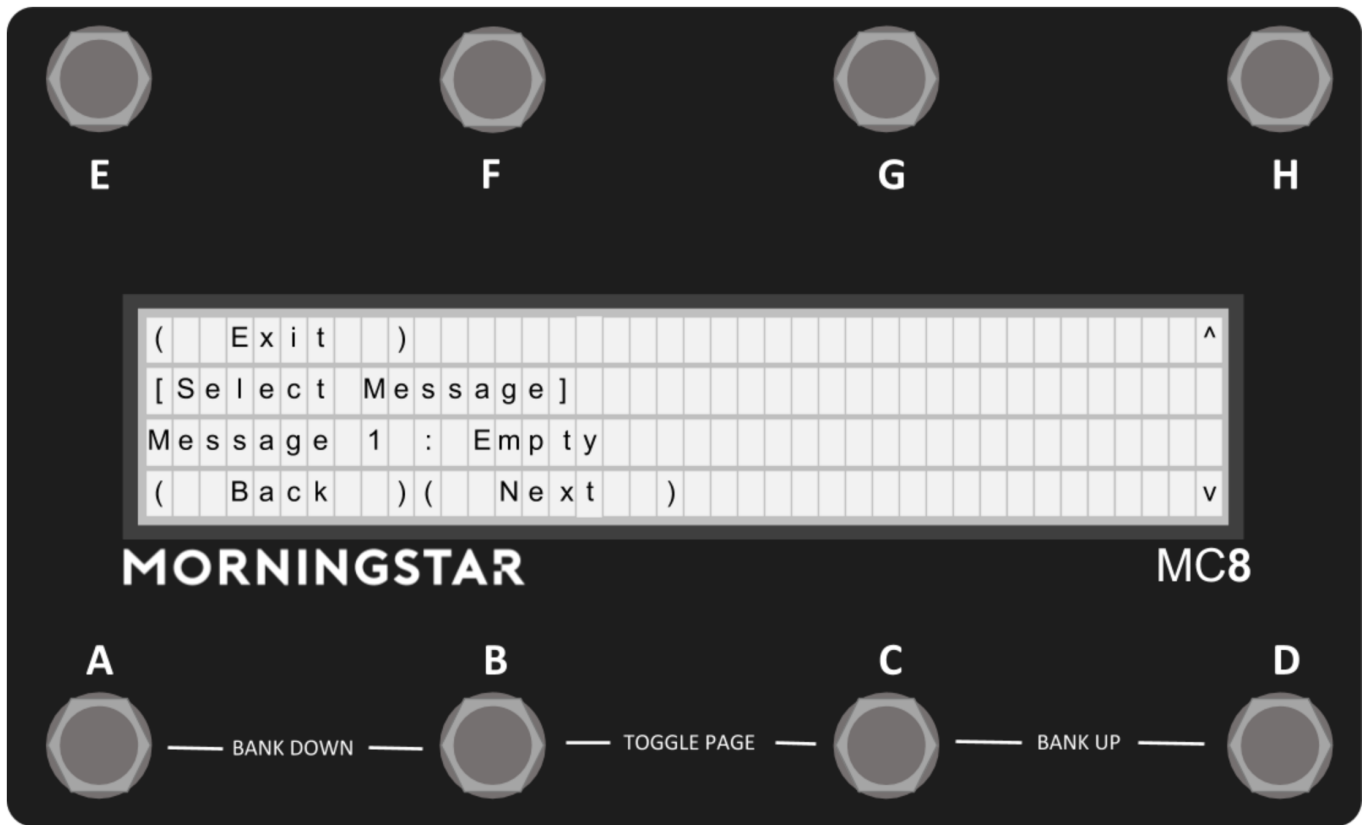

Selecting a Message to Edit

When you enter the Edit Msg interface, the screen above will show. In this screen, you can view the current Midi Type that is assigned to that message. It also indicates the current message that is selected for editing. Pressing `Next` will allow you to edit the selected message. Selecting `^` or `v` will allow you to scroll through the list of 16 messages to edit.

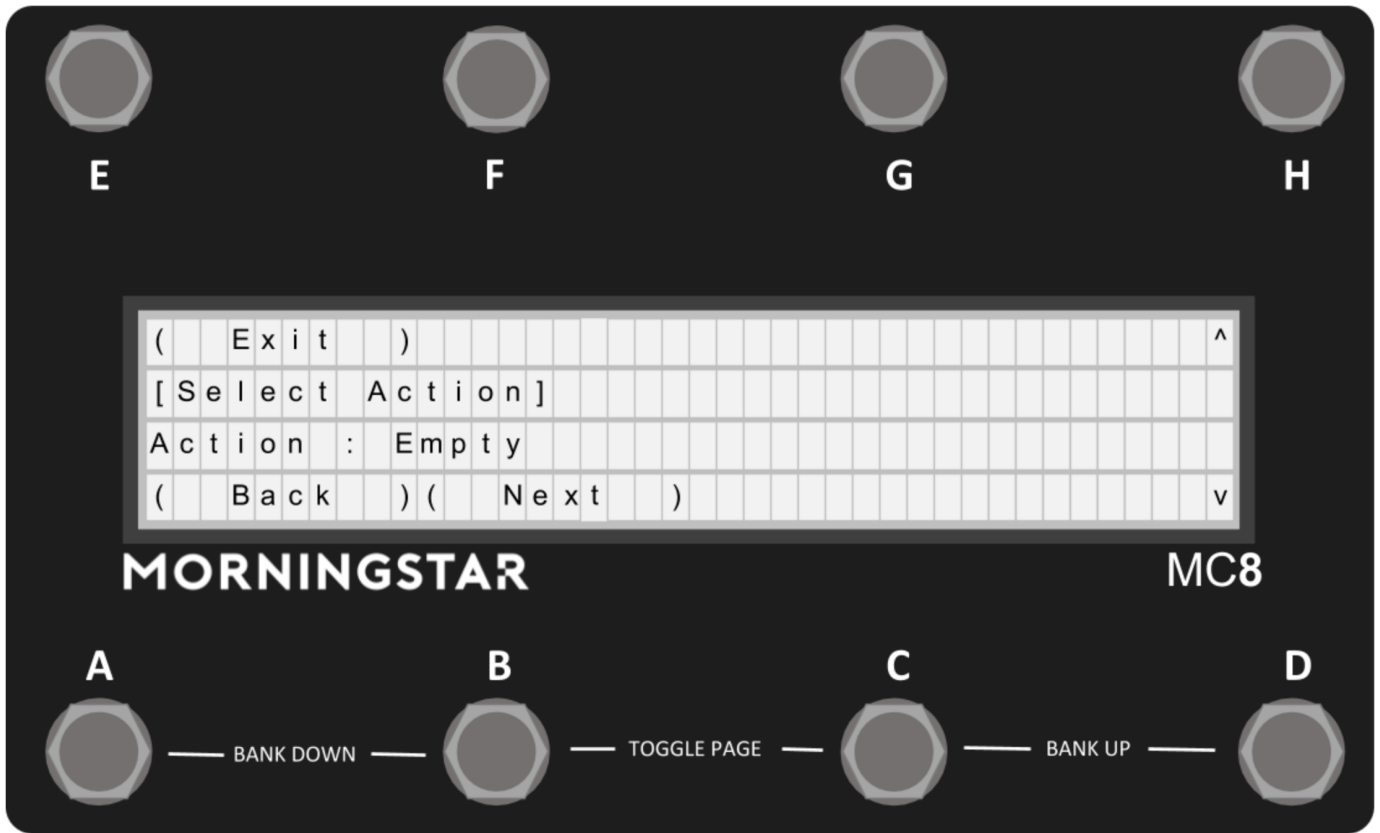

Edit Action

The next menu allows you to select the action to assign to the message. Once selected, each time that action is carried out on the corresponding preset switch, only the messages assigned to that action will be invoked.

Edit Toggle Position

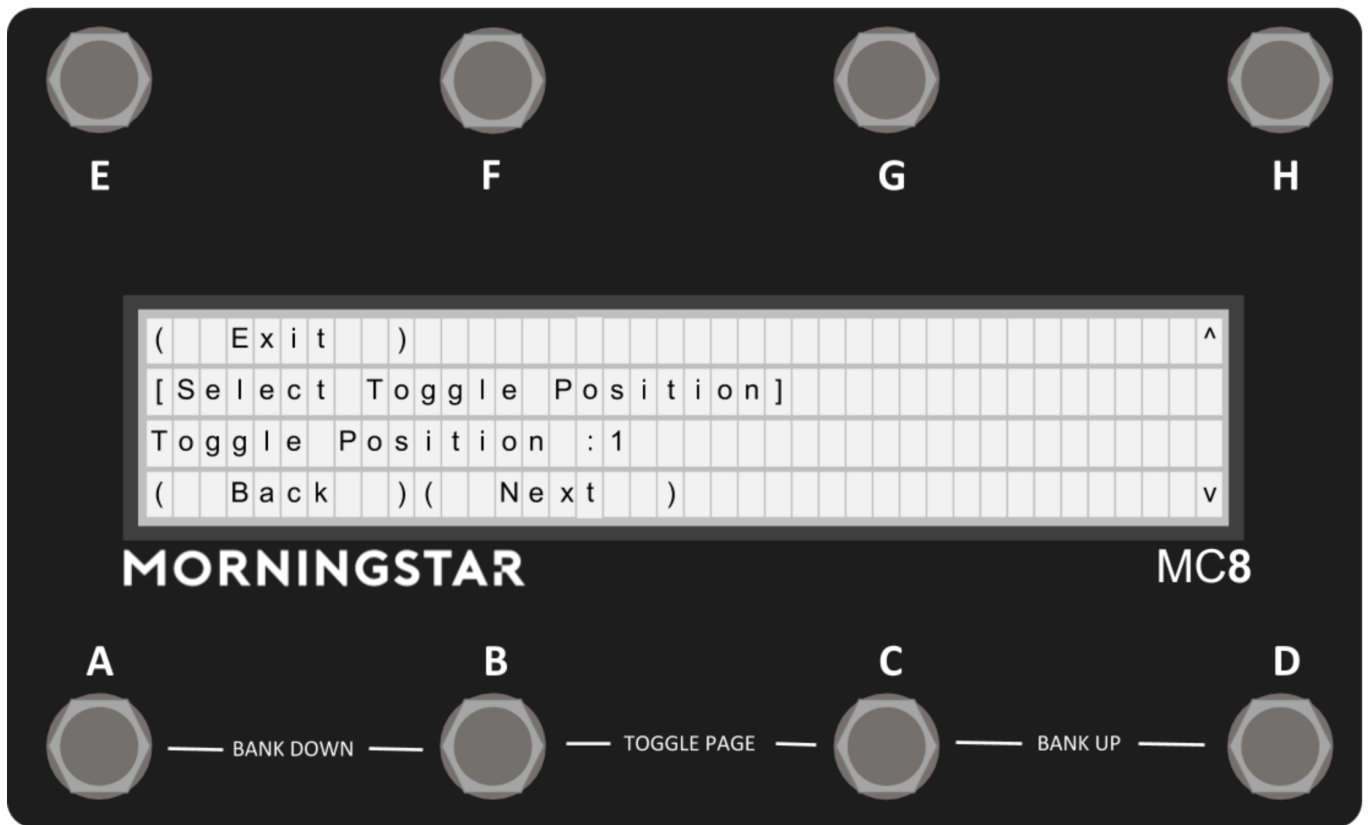

The next menu allows you to edit the message toggle position. Select between 1, 2 and Both. This allows only the messages that match the current preset toggle position to be invoked.

Edit Type

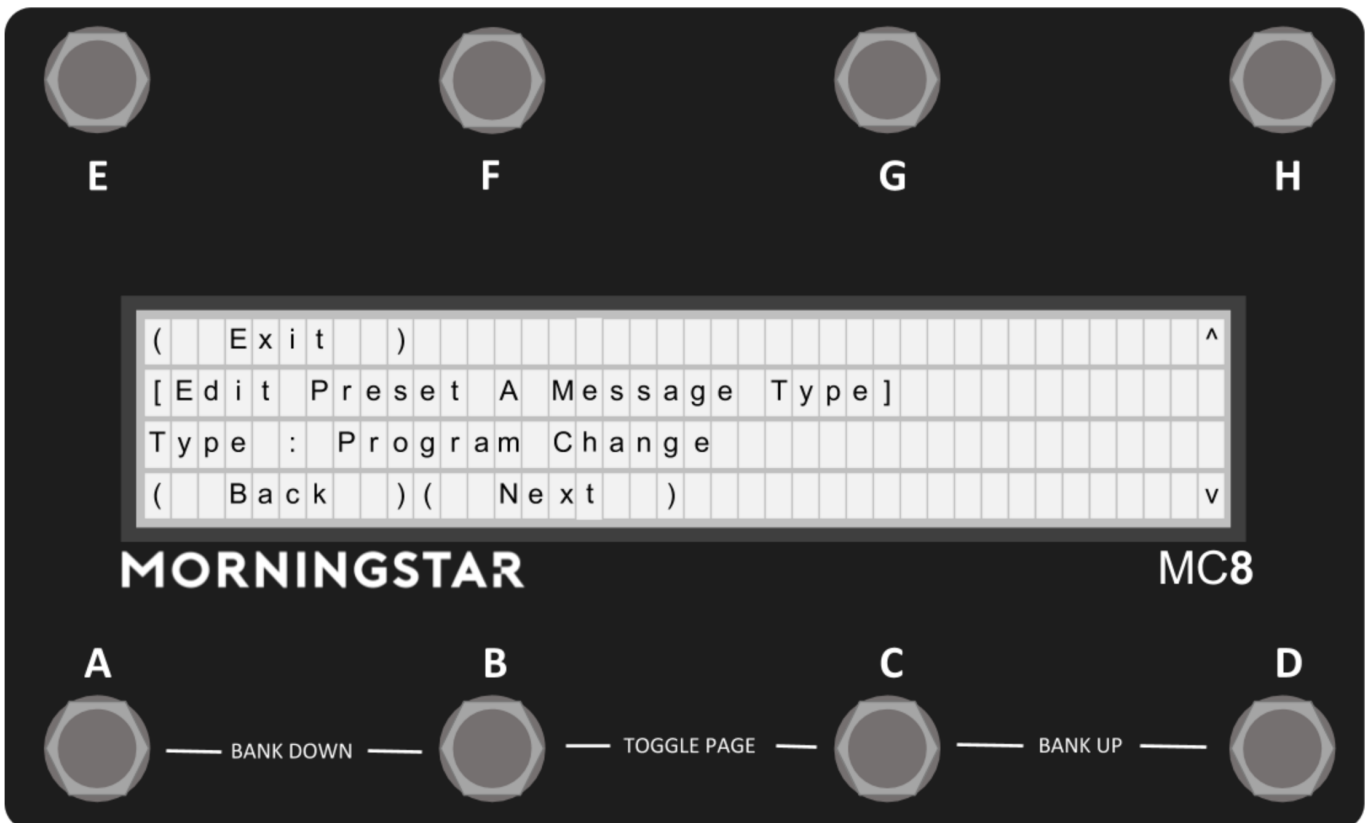

The next menu allows you to edit the Message Type. Scroll up and down to select the Midi Type that you want to be associated with the message. You can read about the full list of Midi Types available in the Glossary.

Edit Type Parameters

Depending on the Midi Type that is selected in the previous menu, unique parameter edit menus will be loaded. Edit your parameters and then press Save on the last page to save your settings.

Toggle Mode

i How to toggle between two different MIDI messages on your MC8 with the same switch
📺 Video tutorial available here: <https://youtu.be/VEr0TB58EgA>

Using the Web/Desktop Editor

Setting up a toggle message is easy. On the editor, there is a toggle option labelled `Preset Toggle Off` on the top left of the interface. Switch it to `On` to enable toggling for the preset.

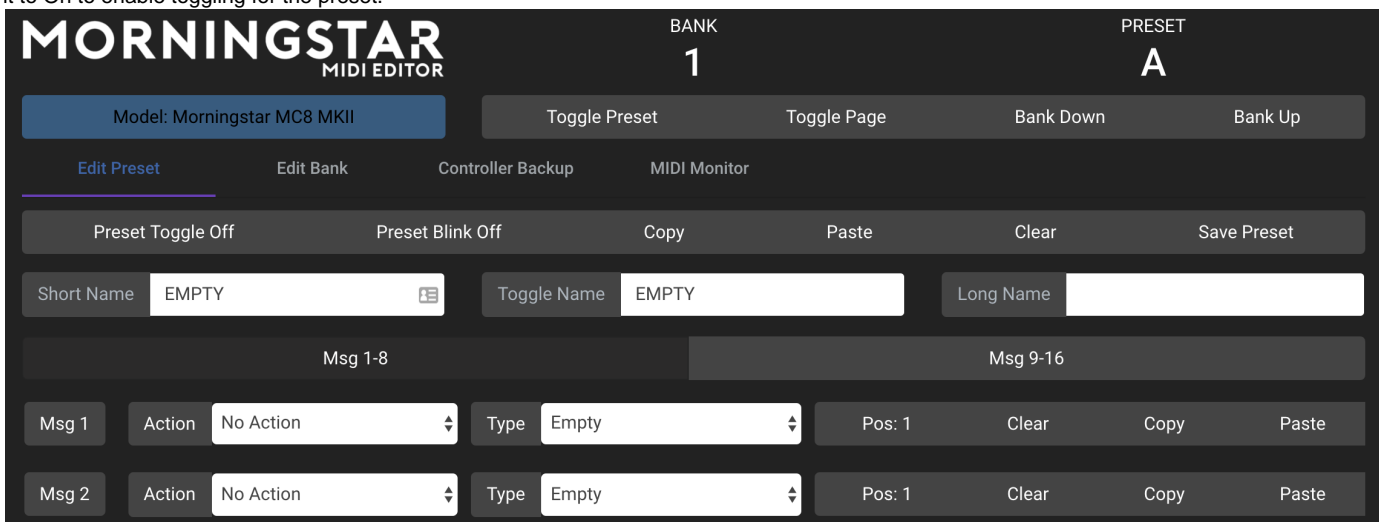

How it works

Each preset on the MC8 allows you to toggle between two positions: 1 and 2. By default, the presets are on toggle position 1. If you switch the toggle position to `ON`, each time the preset is engaged, it will toggle to the other position (between 1 and 2).

Each message also has a position option, where it will be sent out only when the position of the message matches that of the preset. Hence, if you set `Msg1` to be a `PC` message in `Pos 1`, and `Msg2` to be a `PC` Message in `Pos 2`, and you have your toggle on for the preset, each press will toggle between `Msg 1` and `Msg 2`.

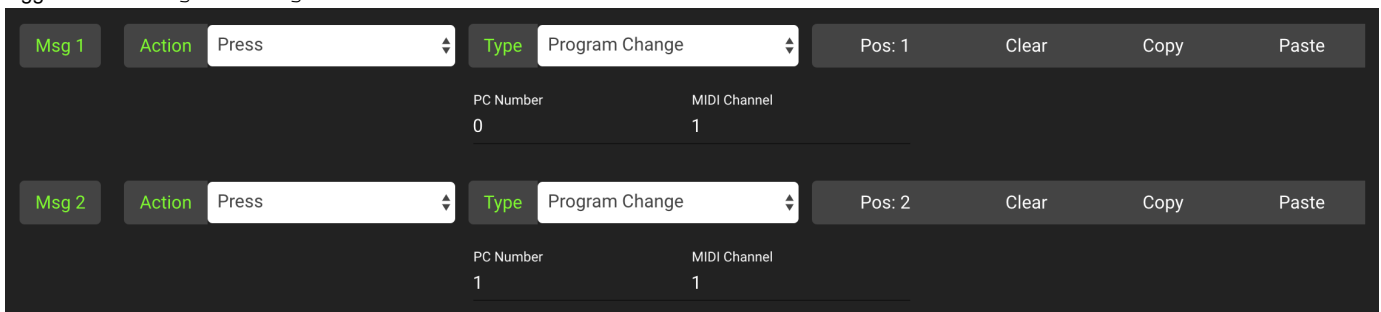

Toggle Name

When the preset is in position 1, the Short Name will be displayed. When the preset is in position 2, the Toggle Name will be displayed.

Blinking

To indicate that the preset is in position 2, you can also use the blink option, where if the blink option is set to On, the Toggle Name on the main page will blink when the preset is in position 2.

Using the built-in MC8 editor

After going into the preset edit menu, go to Page 3 of the menu.

The Toggle button toggles between Toggle On and Toggle Off position for the preset, which the Blink button toggles between Blink On and Blink Off position for the preset.

When editing individual messages, there will be an option to select the toggle position for the message you are editing. Choose between position 1 or 2 accordingly.

Editing Expression Messages

To edit expression messages, press switch D + F first, which will bring you to the edit page, and then select the expression option.

Expression Edit Menu (Page 1)

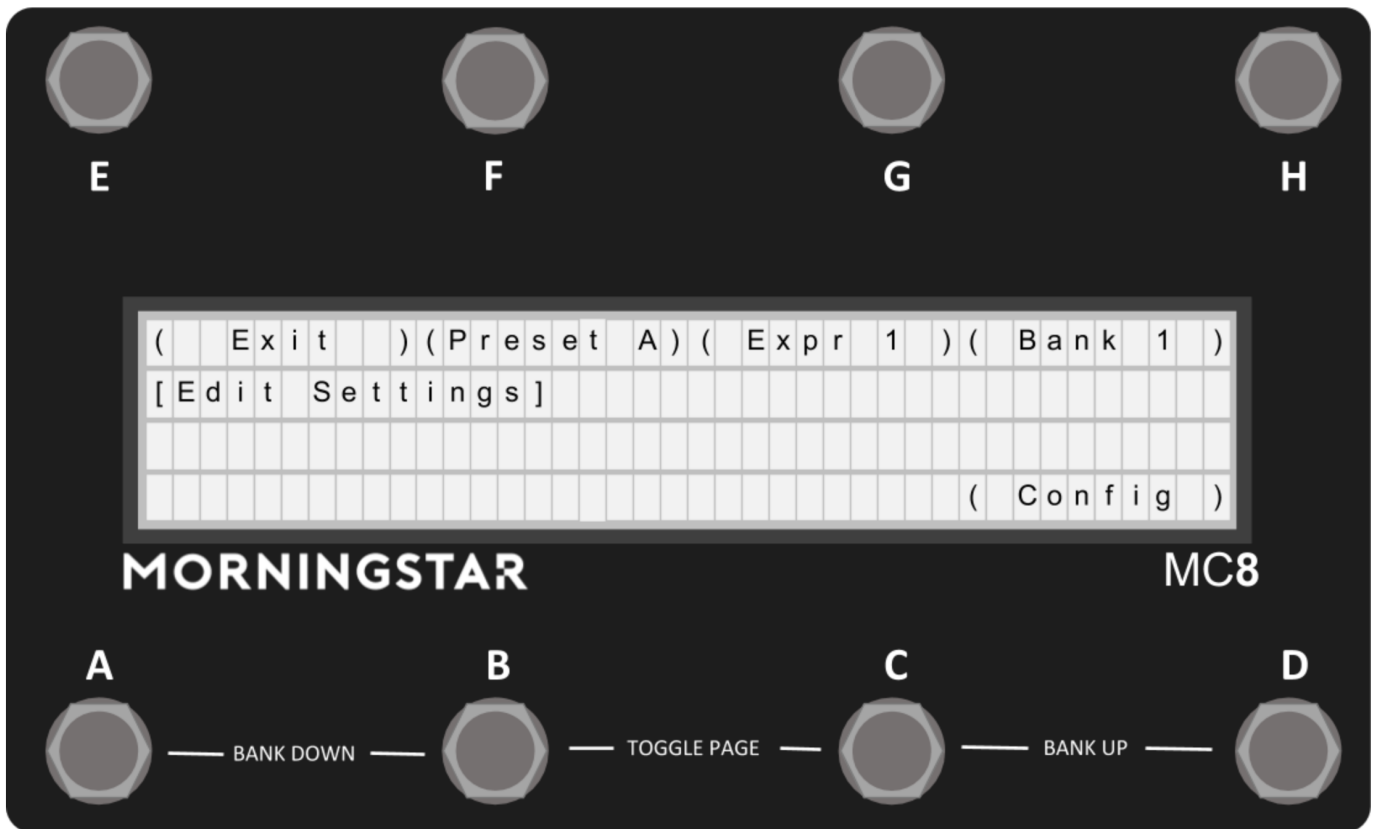

The first page of the menu for editing Expression Messages are the same as that for editing Preset Messages.

Expression Edit Menu (Page 2)

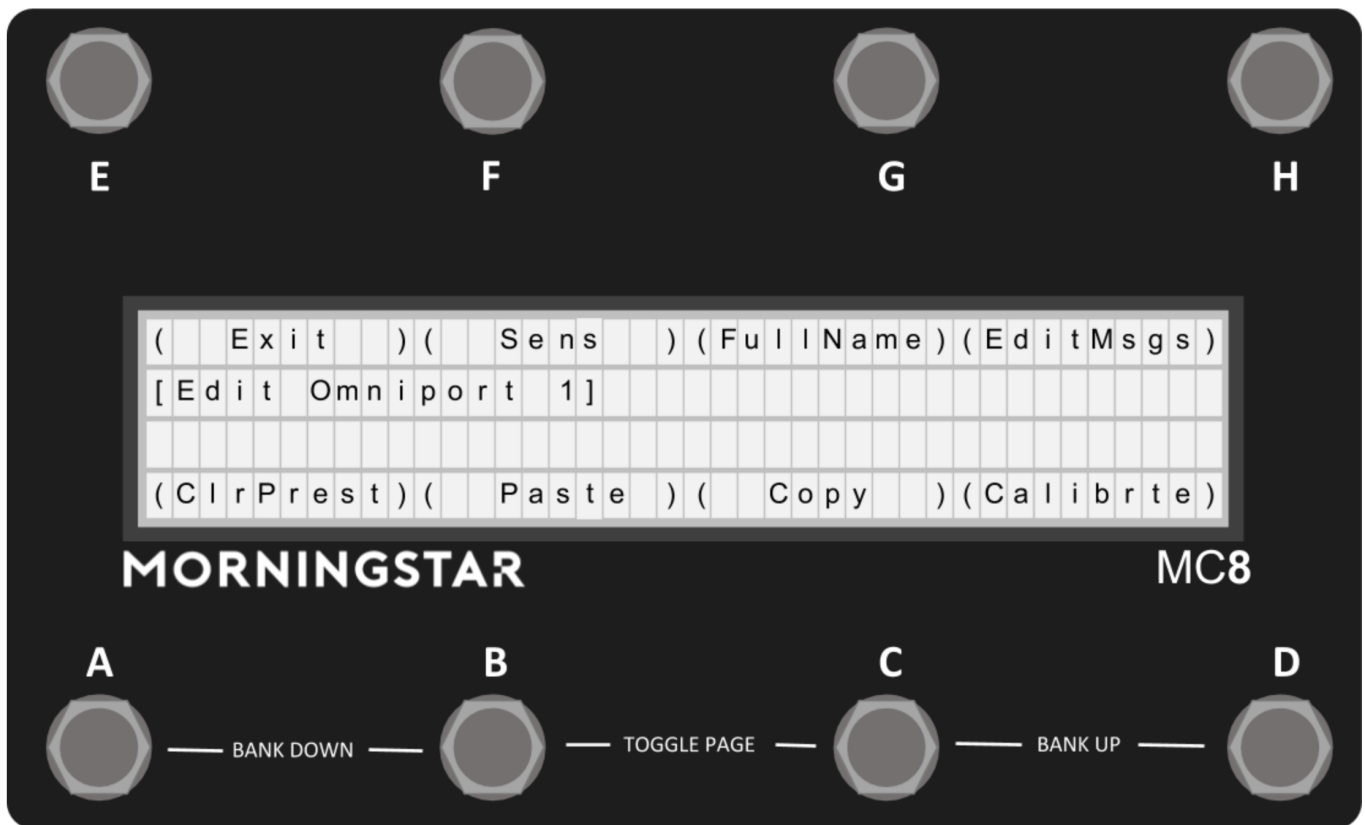

On the second page, you have the option to edit the Full Name, Sensitivity or calibrate your expression pedal. You'll also have the option to Copy or Paste Expression presets, or clear out your expression preset.

Edit Full Name

When the expression pedal is being used, you have the option of displaying a Name for your expression preset. Simply edit and save the name to your expression preset. See Editing Names for more information after entering the FullName option in the Expression Edit Menu.

Calibrating your Expression Input

It is best to calibrate your expression pedal before use to get the optimum performance. Simply go into the Calibrate setting in your Expression Edit Menu. Once there, follow the instructions in the LCD. First set your expression pedal to a heel down position. Ideally, the value should be displayed as 0. Press Next. Next, set your expression pedal to a toe down position. Ideally, the value should be displayed as 127. Press Save to save your settings. Do not worry if you can get a value of 0 and 127 in both positions. Once your setting is saved, the MC8 will optimise the settings to get the most out of your expression pedal.

 The MC8 works with an expression pedal with a Linear potentiometer only. Log potentiometers will not work well.

Setting your Expression sensitivity

Depending on the potentiometer value used in your expression pedal, you may have to edit the sensitivity to get optimum performance. We recommend using expression pedals with 10k potentiometers. The sensitivity setting is used mainly to remove jitters, where the value sent by the MC8 might bounce between 2 values very quickly.

Editing Bank Settings

To enter the bank settings, press Switch D + F, which will bring you to the edit page, and then select the Bank option.

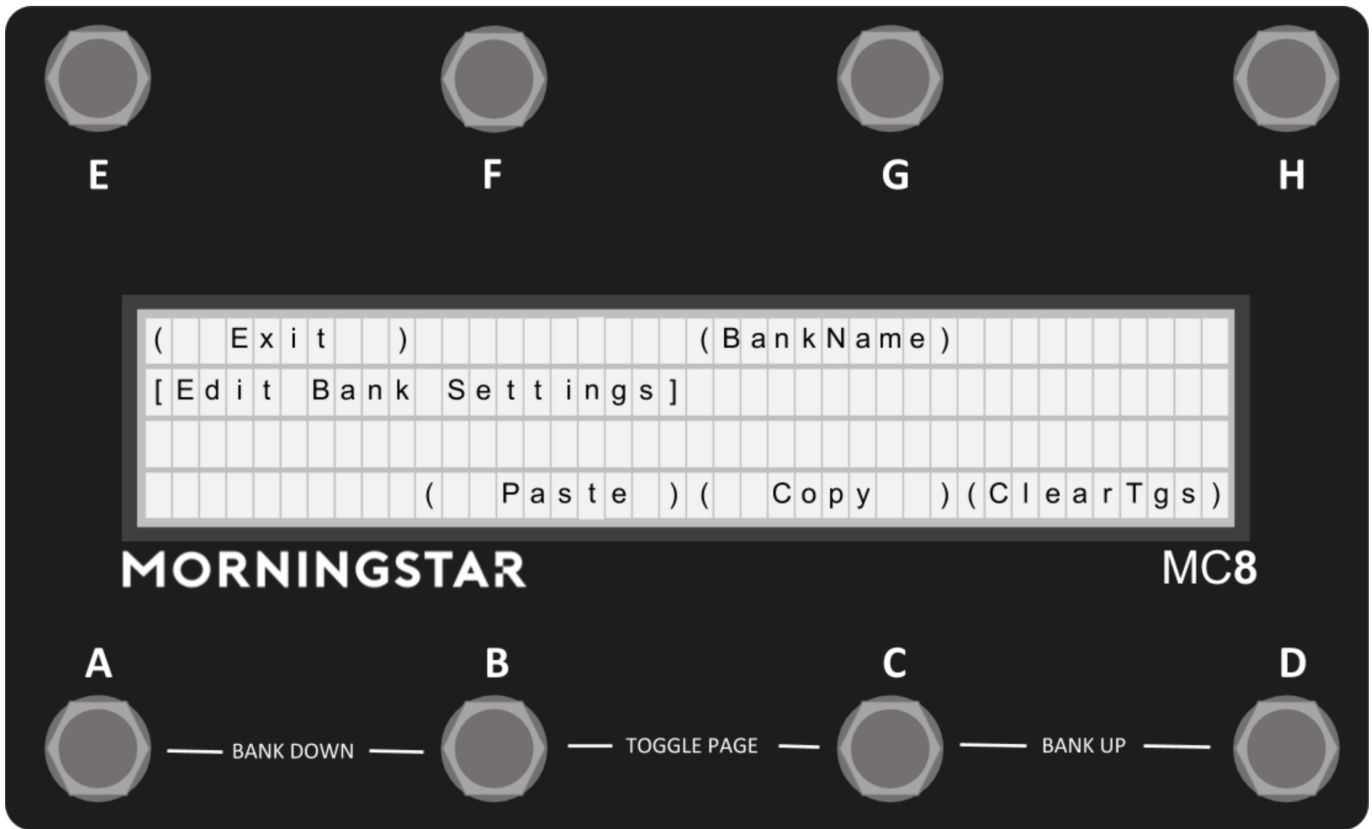

In the edit bank interface, you can edit the Bank Name as well as copy and paste banks.

Bank Name - Edits the Bank Name.

Copy - Copies the current bank.

Paste - Paste the previously copied bank to the current bank.

ClearTgs - Toggles the Bank Clear Toggle feature between On and Off. This feature allows you to disengage the rest of the preset toggle positions except for the preset that is just engaged. This is useful when you want the last-engaged preset to blink.

Editing Names

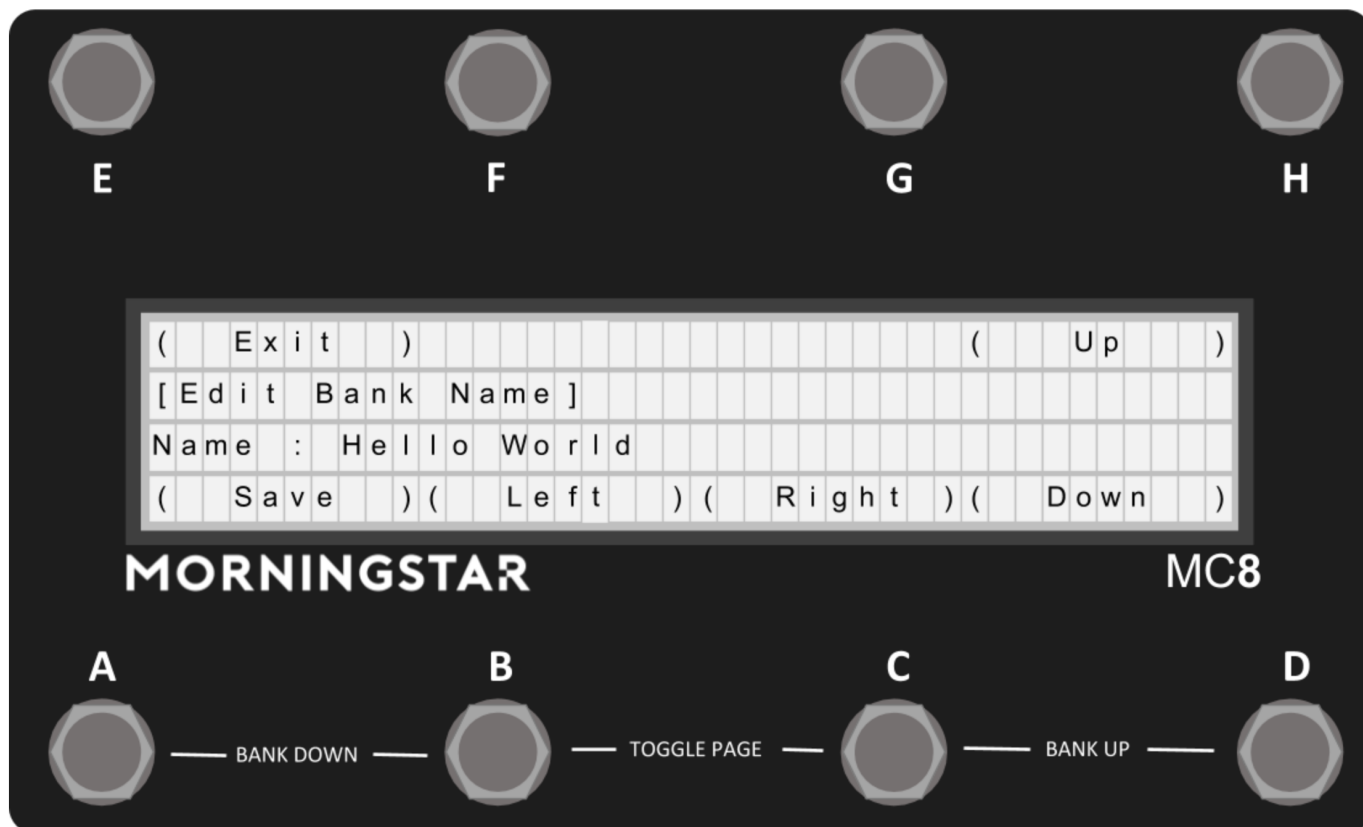

When editing any of the MC8 names like Preset Short Name, Toggle Name, Long Name, or Bank Name, this interface will be display on the screen.

It is possible to display the PC Scroll number in the Preset name by using a placeholder %E0 to %EF. Since there are 16 slots in the PC Scroll function, %E0 will display the number in the first slot, while %EF will display the number in the 16th slot. %E1 will display the number in the second slot.

The count goes as such: 0, 1, 2, 3, 4, 5, 6, 7, 8, 9, A, B, C, D, E, F

If you use %F, this will offset the counter by 1, so the name will indicate 1-128 instead of 0-127.

(Left) - Move the curser to the left.

(Right) - Move the cursor to the right

(Up) - Select the next character

(Down) - Select the previous character

(Save) - Saves the name into memory.

(Exit) - Exits the interface.

MIDI Editor

i Besides using the on-board MIDI editing features on the MC8, you can also edit your settings via the Web/Desktop editor. The Web Editor will always contain the latest developments, while the Desktop editor will be updated less frequently.

Using the Web/Desktop Editor with your MC8

The links are available on our website here: <https://www.morningstarfx.com/editor>

NOTE: A number of functions are disabled when the device is in Editor mode. When using or testing the MC6 with other devices, please remember to toggle out of editor mode.

The Manual for the Editor can be found here: [MIDI Editor](#)

Firmware Update

i We are constantly updating the firmware to include new features and bug fixes.

📺 Video tutorial - How to update your firmware: <https://youtu.be/wtvX8Y9LzXo>

What to download

You'll need to use the Firmware Uploader software to upload the firmware to your device.

Download the latest Firmware Uploader software [here](#).

Download the latest firmware [here](#)

Upload instructions

Open the Firmware Uploader

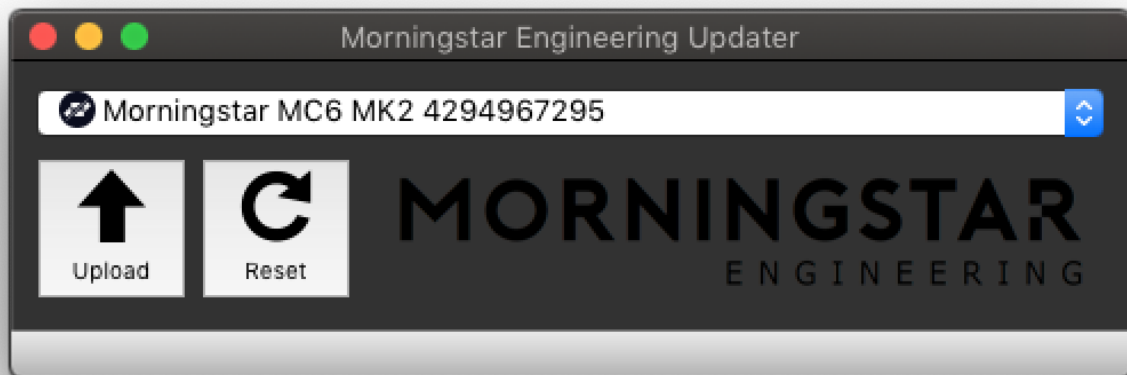

If your device is connected, it will appear in the Firmware Uploader software.

Click on Upload and select the firmware .hex file.

The firmware should then begin uploading and should take only a couple of seconds. Once it is completed, your device will restart with the new firmware.

Troubleshooting

In the rare event where your device upload is not successful, the device might appear to be bricked with blocks showing across the LCD screen. Do not worry and follow these steps:

1. Download the latest firmware from our website.
2. Remove the back cover for your device and locate the reset button.

3. While the device is connected to your computer via USB, and with the Firmware Uploader open, press the reset button location on the PCB.
4. Once pressed, the Firmware Uploader should detect the device. Thereafter, repeat the above upload procedure.

MIDI Implementation

 MIDI implementation chart for the MC8.

The MC8 can respond to **CC** and **PC** messages from the USB MIDI port and MIDI IN port to execute specific functions. You can send **PC** or **CC** messages via an external MIDI controller or software to control the MC8 functions specified below.

PC Messages

PC messages will change the banks on the MC8, where a **PC#0** message will engage Bank 1, and **PC#1** message will engage Bank 2, and so on.

CC Messages

Function	CC#	Value
Bank Up	0	any
Bank Down	1	any
Set Toggle (All)	2	127
Set Toggle (Individual)	2	0 - 21 0 = Preset A 1 = Preset B ... 20 = Preset U 21 = Preset V
Clear Toggle (All)	3	127
Clear Toggle (Individual)	3	0 - 21 0 = Preset A 1 = Preset B ... 20 = Preset U 21 = Preset V
Page Toggle	4	any
Engage Preset	10 - 31 10 = Preset A 11 = Preset B ... 30 = Preset U 31 = Preset V	0 = Do Nothing
		1 = On Press
		2 = On Release
		3 = On Long Press
		4 = On Long Press Release
		5 = On Double Tap

		6 = On Double Tap Release
		7 = On Double Tap Hold
		8 = On Double Tap Hold Release
		9 = On Release All
		10 = On Long Press Scroll
Set MIDI BPM (MSB 2 bits)	5	0-127
Set MIDI BPM (LSB 7 bits)	6	0-127
Engage Expression 1	51	0-127
Engage Expression 2	52	0-127
Engage Expression 3	53	0-127
Engage Expression 4	54	0-127